



The quest for Interoperability within Ocean Sciences

*C. Waldmann, University of Bremen, Germany
(waldmann@marum.de)*

The expectations on the benefits of ocean observatories are high which is related to the fact that unprecedented efforts have to be started to set them in place. The Ocean Observatory Initiative in the US has embraced this into the following statement - The OOI will transform research of the oceans by establishing a network of interactive, globally distributed sensors with near real-time data access, thereby enhancing our capabilities to address critical issues such as climate change, ecosystem variability, ocean acidification, and carbon cycling. Recent technological advances in sensors, computational speed, communication bandwidth, Internet resources, miniaturization, genomic analyses, high-definition imaging, robotics and data assimilation-modeling-visualization techniques are opening new possibilities for remote scientific inquiry and discovery.

Ocean Observatory Initiative, 2009

The above statement already gives a flavor of the extent of complexity which has to be addressed. Descriptions of complex systems can be simplified by breaking them down into simple functional blocks. This approach allows stakeholders to get an overview without getting to know all details and based on that it allows discussion and decision-making on implementation and operation strategies. Ocean observatories surely belong to the category of complex systems like the infrastructure itself and the operation covers a wide range of technologies and methods. Furthermore to identifying functional blocks the interaction between them has to be defined. Technically speaking this means that interfaces have to be specified. If functional blocks are to be made interchangeable the concept of interoperability is introduced. A definition of what interoperability means can be found in the glossary of terms of the IEEE Standards Dictionary -

Interoperability is the ability of two or more systems to exchange information and use the information that has been exchanged mutually. (ISO/IEC 14252: 1995)

This is quite general and in a sense vague. Therefore more specific definitions are considered like -

Interoperability is the capability, promoted but not guaranteed by joint conformance with a given set of standards that enables heterogeneous equipment, generally built by various vendors, to work together in a network environment.

The quest for Interoperability within Ocean Sciences

pág. 1

Interoperable Data Management and Instrument Control

pág. 3

PESOS Group on Standardization

pág. 7

Evaluation of Standards in OBSEA

pág. 8

Instrument Interface Standards for Interoperable Ocean Sensor Networks

pág. 11

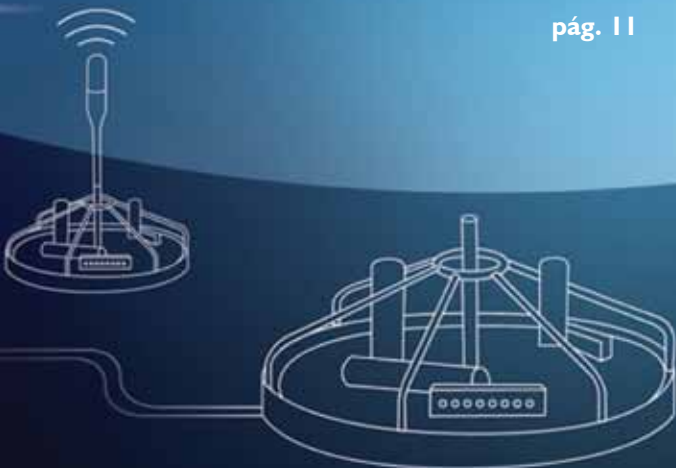

This definition elucidates the relationship between standards and interoperability namely that standards allow for interoperability.

The implications of the above for ocean sciences are manifold. Due to the diversity of application areas the definition of interoperability has to be adapted to the respective field, for instance data exchange, sensor integration and platform operation. It will be difficult to break down interoperability concepts to the level of underwater connectors as there are already too many systems in operation which, for good reasons, use differing components.

However, on a higher level interoperability can contribute to a more efficient use of existing systems such as by defining interfaces and workflows that describe instrument integration and operation.

It is well known that already today many ocean instruments have interfaces that comply with accepted standards. That does not immediately mean that they are interoperable.

A common overall architecture is still missing. This has been the starting point of ESONET to investigate standards that are currently in use or standards that can be useful for future ocean science infrastructures.

As an example for the activities within ESONET an interoperability experiment under the auspices of OGC (“Ocean Science Interoperability Experiment Phase II”) has been carried out to evaluate existing standards and in particular to check the maturity of Plug and Work concepts.

With regard to mobile platforms like ROVs and AUVs there is not much head space to add new standards, for instance to simplify the integration of individual instruments into different systems. However, the integration procedure itself and the necessary workflows are the concepts that can be standardized, i.e. can be made interoperable. This idea very much resembles quality management concepts and therefore it also has been addressed within ESONET.

One could think of quality management concepts as forming the framework to interoperability considerations and selected schemes are projected into the respective field. As an example the calibration of instruments will be one part of a High Level Test Plan defined in the respective quality management document. Concepts of Risk Analysis also play a cross cutting role and will be part of the QM scheme for ocean observatories.

Within ESONET the work package that is dealing with these topics is not claiming to deliver an exhaustive description of all concepts that have been touched upon. The goal is to evaluate the practicability and conclude whether they should be recommended. In any case this can only be done through consensus between the partners. Standards and interoperability concepts can not be enforced, they have to prove to be beneficial. As a matter of fact the instrument Network of Excellence that has been introduced by the European Commission within FP 6 is the ideal platform to pursue this type of work. In the following, two articles are presented that give more specific information about the topic.



Fig.1 - The MARUM ROV during recovery – common handling procedures for European ROV systems have been defined and are evaluated during ESONET NoE



Fig.2 - The use of payload scientific instruments on mobile platforms calls for comprehensive description of the integration process

Interoperable Data Management and Instrument Control, Plug and Play Concepts and Sensor Registry Experiences at OBSEA

Joaquin del Rio, Tom O'Reilly, Daniel Mihai Toma, Jordi Sorribas, Eric Delory, Antoni Manuel

*SARTI – UPC Spain; MBARI USA
UTM – CSIC Spain; dBscale Sensing Technologies - Spain*

Introduction

ESONET needs a Web portal with real-time web interface from online observatories.

In order to do so, online data are urgently needed.

This was one strong demand during the 2009 review of ESONET in Brussels.

Actually each observatory has their own software architecture and data management processes. Some standards can be applied on top of each observatory's data management in order to access data from internet in a standard way. Some of these standards can be SensorWebEnable, IEEE1451.0. or initiatives like DataTurbine for high speed real time data streaming.

The use of these standards in an observatory to access data and metadata from a general web interface can provide interoperable data visualization from the user point of view. Another issues, not related with data access or data visualization, are important to archive interoperability between observatories as plug and work capabilities of the instrument. Initiatives as MBARI PUCK protocol (for RS232 or IP), interfaces like the SmartSensorBoard (Ifremer,UPC) or recently the SID, Sensor Interface Descriptor (52North), are being tested at Western Mediterranean Observatory OBSEA (Figure 3).

Other interoperability issues for standardization about access to data archives is now starting at OBSEA taking into account the experience about previous initiatives like SeaDataNet and standards proposed by INSPIRE for metadata specification like ISO19115 and NetCDF for data transport.

Time synchronization in cabled observatories by Ethernet networks can be achieved implementing IEEE1588 Precision Time Protocol (PTP) versus NTP or SNTP for applications with needs of synchronization under milliseconds. Actual observatories had been deployed before IEEE1588v2 was released, and for these reason junction boxes are not equipped with IEEE1588v2 Ethernet switches. Some test experiments has been carry out in order to test PTP under non PTP switches in order to evaluate the time synchronization accuracy for these type of networks. Figure 6 shows one of the test setup to provide GPS information to an instrument through a IEEE1588 synchronization network.

About OBSEA

OBSEA is a cabled seafloor observatory 4 km offshore Vilanova i la Geltru (Barcelona, Spain) coast located in a fishing protected area, and interconnected to the coast by an energy and communications mixed cable.

The main advantage of having a cabled observatory is to be able to provide power supply to the scientific instruments and to have a high bandwidth communication link. In this way, continuous realtime data is available. The proposed solution is the implementation of an optical Ethernet network that transmits continuously data from marine sensors connected to the observatory. With OBSEA, we can perform a real time observation of multiple parameters in the marine environment. SARTI research group from the Technical University of Catalonia (UPC) is devoted mainly in the design and deployment of sensor networks, from the electronic, mechanical and data management point of view. In this case, OBSEA was a new challenge, and now it is a perfect place where scientist are able to collect data, test new instrumentation and procedures.

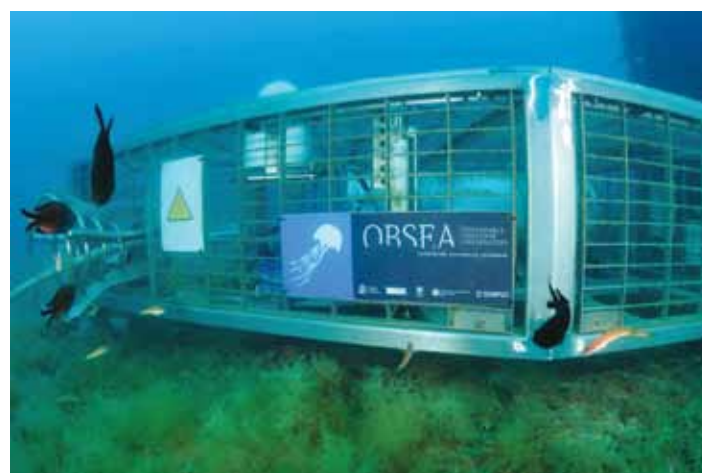

Fig.3 - OBSEA Structure: this cabled observatory is located in 10 m depth and is now operational for one year.

From the land station we provide power supply and fibre optics communication link Furthermore we have installed a general alarm management to detect any failure in the system and/or in the storage capacity. The land station is connected at the beach dock through a cable of 1000 m, from where the marine cable starts its route to the main node, 4 km offshore and at 20m water depth.

IEEE-1451 and OGC SWE Integration into Actual Observatories

In most cases, actual observatories are using a proprietary Data Management and Instrument control framework. We can divide the interoperability problems in different parts from bottom (instrument or sensor side) to top (user access to real-time data and archive). At figure 4 we can see a sim-

ple approach to achieve interoperability to real time data. The integration at the actual proprietary Data Management system of different observatories of different services like IEEE1451 server or SWE SOS server can offer access to data using web clients without disturbing the actual functionality off the observatory.

The IEEE 1451 provides a specification to add a digital layer of memory, functionality, and communication to sensors. For example it enables sensors to be controllable and their measurements accessible through a network with sufficient information on the sensor characteristics and history.

OGC Sensor Web Enablement (SWE) provides a specification to Web-enabled sensors to be accessible and, where applicable, controllable via the Web. SOS provides a broad range of interoperable capability for discovering, binding to, and interrogating individual sensors, sensor platforms, or networked constellations of sensors in real-time, archived or simulated environments.

IEEE-1451 and OGC SWE are rather complex, which is to be expected as these standards are also quite comprehensive. This complexity presents challenges for instrument manufacturers who must thoroughly understand the standard and who must correctly implement it in firmware.

Moreover embedded instrument processors are often designed for low cost and low-power environments, and hence may not be capable of fully implementing the standards.

Another drawback is that manufacturers would likely have to abandon existing instrument firmware that does not implement the standard; this existing firmware often represents a very considerable investment by the manufacturer.

A third drawback is that IEEE-1451 and OGC SWE are still evolving, again due to the comprehensive nature of these standards. Thus either the standard revision process must be very carefully managed to ensure “backwards compatibility”, or instrument firmware must be occasionally upgraded to remain compliant with the latest standard.

Both of these alternatives present non-trivial challenges to instrument manufacturers and standards bodies.

For these reasons, up to now, we can consider these standards in the top level services to provide real-time data to users in a standard way.

Sensor Registration in ESONET’s SDI

The ESONET sensor registry is largely based on the OGC SWE architecture concept. The creation of templates for registering ESONET observatory instruments required pre-establishing the requirements, starting with a feature matrix and registration interface prototype that account for the various sensing technology areas, i.e. biological, physical, chemical, and multiparameter instruments. As all collected specifications have to be mapped to a dictionary for metadata discoverability and computer usability, the on-line templates for registration have been designed accordingly, for example using standard methods and common practice or de facto standard ontologies. The metadata format follows an internationally recognized standard, SensorML, which was chosen according to the following criteria: availability of open transformation tools, medium/low-complexity, ESONET scientific and system architects consensus, and global interoperability. Sensors are attributed a unique identifier. Part of the work was to organize the collection of instrument specifications and eventually make a proposal for a multi-science use case scenario, so as to evaluate the quality of, and identify gaps in, the registration process. Besides providing feedback on the effort for future improvements, this use case scenario will demonstrate the benefit of the project. The following picture is a screenshot of the ESONET Sensor Registration Interface (current test URL: vps.db-scale.com:8080/esonet , at a later stage the registration interface will be accessible from ESONET SDI portal through secured access). Available functions include mapping of IEEE1451 Transducer Electronic DataSheet XML mapping.



PUCK Protocol and SensorML with Sensor Interface Descriptor (SID)

Another approach for instrument manufacturers is to implement PUCK protocol in their instrument firmware. PUCK has been formally proposed as an OGC Sensor Web Enablement standard. PUCK does not itself fully implement interoperability, but rather provides the lower tier in a hierarchy of standards that achieve

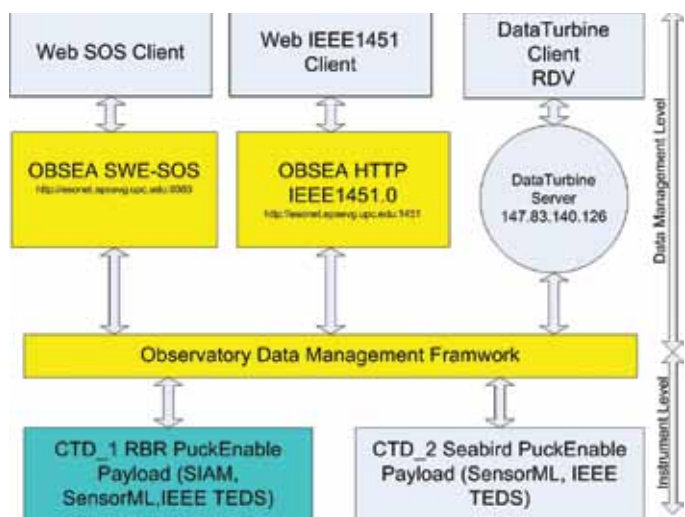

Fig.4 - Access to real-time data using standards like SWE SOS or IEEE1451

this goal. PUCK protocol is a simple command protocol that helps to automate the configuration process by physically storing information about the instrument with the instrument itself. The protocol defines a small “PUCK datasheet” that can be retrieved from every compliant instrument; the datasheet includes a universally unique identifier for the instrument as well as metadata that includes manufacturer and model. Additional information called “PUCK payload” can be stored and retrieved from the instrument. The payload format and content are not constrained by PUCK protocol, and can include executable driver code that implements a standard operating protocol as well as metadata that describe the instrument in a standard way, or any other information deemed relevant by the observing system. PUCK protocol commands augment rather than replaces existing instrument commands, and so manufacturers do not have to abandon their existing software. PUCK protocol is simple, and readily implemented in even simple instrument processors; several manufacturers now implement MBARI PUCK protocol in their instruments. PUCK protocol was originally defined for instruments with an RS232 interface. A proposed revision extends the protocol to Ethernet interfaces; the “IP-PUCK” protocol includes the use of Zeroconf to enable easy installation and discovery of sensors in an IP network.

The OBSEA team has developed an automatic algorithm to detect the installation of RS-232 PUCK instruments. The host computer periodically interrogates the serial ports for a PUCK enabled instrument. When the host receives a PUCK response from the serial port, the host retrieves the UUID to determine if a new instrument has been installed. If so, the host retrieves the PUCK payload and uses this information to collect data from the instrument and register it in WEB using standards like IEEE 1451.0 or OGC SWE. The detection algorithm for IP PUCK-enabled instruments is based on the Zeroconf standard. When an IP PUCK instrument is plugged into a local area network (LAN), it automatically gets an IP address and is registered as a PUCK service via Zeroconf. An application that runs in the same LAN can discover the instrument and retrieve the PUCK payload through PUCK protocol and automatically register the new instrument in a standard way in WEB.

Thus standard IEEE-1451 and OGC SWE components can be automatically retrieved and installed by the host when a PUCK-enabled instrument is plugged in, overcoming the difficulties of manual installation.

An important component to achieve the plug and play capability with PUCK protocol is the payload information attached to each instrument. The payload should describe entirely the functionality of the instruments in a standard way and should be machine and human readable. To accomplish this task SensorML with Sensor Interface Descriptor (SID) can be used, which provides standard models and an XML encoding for describing sensors, measurement processes, and instrument control information. As we know, instruments are using proprietary command protocols to communicate. The development of software drivers is needed in order to integrate them in each platform. SID can help to avoid the process of write instrument drivers. The generation of a machine readable document with information about how to communicate and parse the information will help the plug and play process.

Figure 5 shows how services running a SID interpreter can establish the connection to a sensor and are able to communicate with it by using the sensor protocol definition of the SID. SID instances for particular sensor types can be reused in different scenarios and can be shared among user communities.

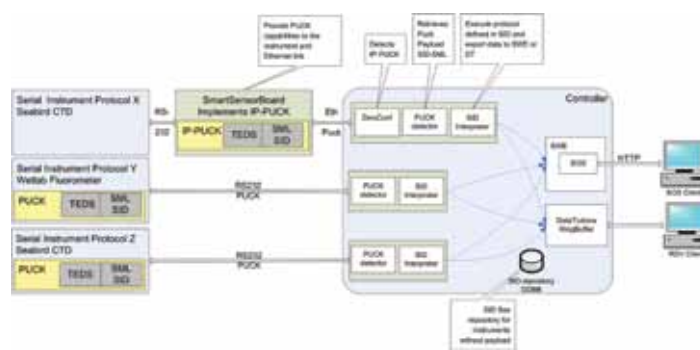

Fig.5 - SID interpreter in a data Acquisition System (proposed to OGC by 52North)

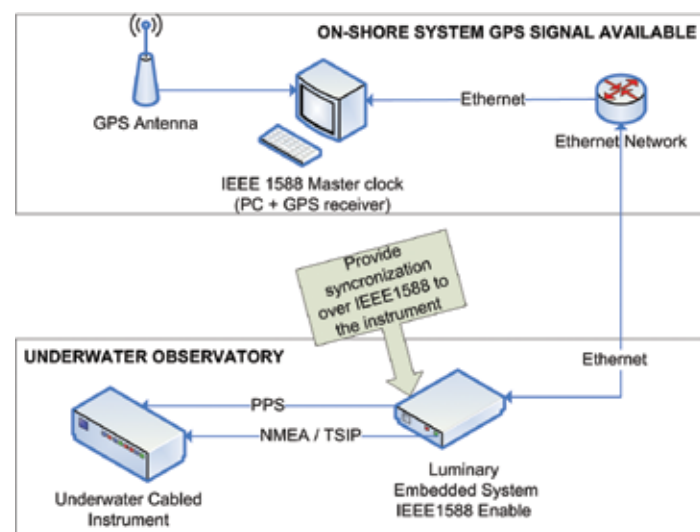

Fig.6 - Testing IEEE1588 PTP for underwater instruments

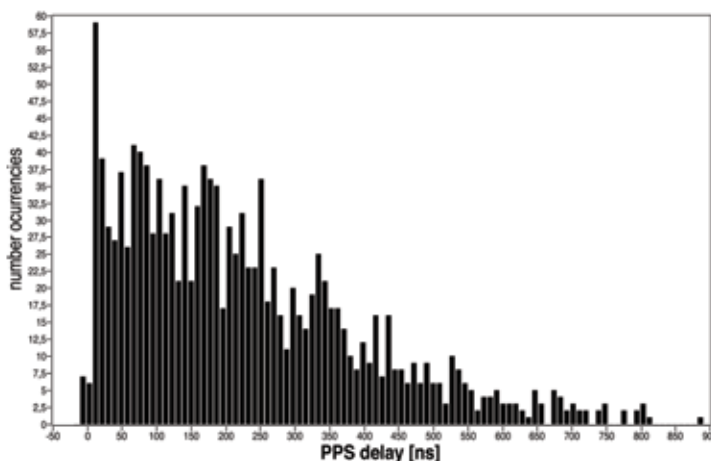

Fig.7 - PPS signals delay histogram with PTP IEEE1588v1 using COTS Ethernet Switch.

The Smart Ocean Sensors Consortium

The Smart Ocean Sensors Consortium (SOSC) is a group of manufacturers and users dedicated to improving the reliability, utility and economy of hydrographic sensor networks. The SOSC aims to accomplish these goals through the development, adoption and promotion of practical standard interfaces and protocols. The SOSC was founded on the initiative of Canadian instrument manufacturer RBR Ltd in early 2009 following an OGC-sponsored interoperability workshop in St John's Newfoundland. Neil Cater of Memorial University's Marine Institute was elected first consortium chairman. Sensor manufacturer members include European companies SEND Electronics GmbH and SiS GmbH, as well as manufacturers from Canada and the USA. Non-manufacturer members include representatives from ESONET, SARTI-UPC, the Monterey Bay Aquarium Research Institute (MBARI), the US Ocean Observatories initiative, NOAA, and other organizations. Members pledge to offer and use instruments that comply with interfaces and standards designated as "consortium approved". Membership is open to organizations that share consortium goals, and membership requests are subject to approval by the SOSC chairman.

The SOSC collaborates with the Open Geospatial Consortium (OGC), which has established the Sensor Web Enablement suite of interoperability standards. The two consortia have signed a formal memo of understanding, resolving that they will cooperate to pursue common goals. SOSC manufacturers plan to provide a standard description of each of their instruments, and are evaluating the OGC's SensorML markup language for this purpose. The manufacturers also agree to define a standard protocol to uniquely identify the make, model, and serial number of each compliant instrument. The two consortia have agreed to collaborate on formal submission of PUCK as an OGC standard. Instrument manufacturers provided very useful feedback to the OGC standard working group during this process, and SOSC member SARTI-UPC has actually implemented an "Ethernet PUCK" instrument to verify the feasibility of the proposed standard. The SOSC and OGC also work together to demonstrate sensor network technologies such as PUCK, OGC Sensor Web Enablement, IEEE 1451, and other standards. These "live" demonstrations are held at conferences, and usually involve SOSC-OGC team members and sensors distributed across the planet, integrated in real-time thanks to the Internet and interoperability standards.

Following EU's Maritime Policy on Data and Metadata at OBSEA

The EU's Maritime Policy Blue Book, welcomed by the European Council in December 2007, undertook to take steps towards a European Marine Observation and Data Network (EMODNET) that would improve availability of high quality data. Basic design principles of EMODNET have been formulated by the Commission together with a specially-

constituted Expert Group. These are:

1. Collect data once and use it many times
2. Develop standards across disciplines as well as within them
3. Process and validate data at different levels. Structures are already developing at national level but infrastructure at sea-basin and European level is needed
4. Provide sustainable financing at an EU level so as to extract maximum value from the efforts of individual Member States
5. Build on existing efforts where data communities have already organised themselves
6. Develop a decision-making process for priorities that is user-driven
7. Accompany data with statements on ownership, accuracy and precision.
8. Recognise that marine data is a public good and discourage cost-recovery pricing from public bodies.

The overall objective is to migrate fragmented and inaccessible data into interoperable, continuous and publicly available data streams for complete maritime basins. The EMODNET data and metadata infrastructure complies with European Directive INSPIRE by means of using ISO19115 as the basis for metadata and data sets description. The Common Data Index (CDI), developed under the SeaDataNet framework has been used as basic (metadata formats and technology for access to data sets.

The aim in OBSEA is also to harmonize its data management with the EMODNET metadata and data formats and procedures. In this way the data sets produced in OBSEA could be accessed through EMODNET or SeaDataNet portals using the appropriate mechanisms such shopping basket, authentication procedures, data formats, and common communication standards.

The OBSEA historical data sets will be described and catalogued using CDI metadata files, and ODV ASCII and netCDF with CF conventions file formats will be used for data dissemination throughout OBSEA web portal.

Inside CDI files references to OGC SWE services will be included in order to provide better sensor description and access to real-time data throughout SOS. However metadata fields and vocabularies used should be harmonized and synchronized in order to avoid inconsistencies in system description.



References:

Joaquin del Rio, Tom O'Reilly, Kent Headley, Daniel Mihai Toma, Neil Cater, Carlos Rueda, Duane Edgington, Chris Ng, Ikram Bghiel, Luis Bermudez, Jesper Zedlitz, Frank Johnson, Greg Johnson, Eric Davis, Reo Phillips, Sameer Tilak, Tony Fountain, Eric Delory, Antoni Manu-

el, Christoph Waldman. "Evaluation of MBARI PUCK protocol for interoperable ocean observatories" MARTECH'09.. INTERNATIONAL WORKSHOP ON MARINE TECHNOLOGY. November 2009.

O'Reilly, T., K. Headley, D.R. Edgington, C. Rueda, K. Lee, E. Song, C. Albrechts, J. del Rio, D. Toma, A. Manuel, E. Delory, C. Waldmann, S. Fairgrieve, L. Bermudez, E. Bridger, P. Bogden, and A. Amirault (2009). "Instrument interface standards for interoperable ocean sensor networks". Proceedings of the Institute of Electrical and Electronics Engineers/Oceans Engineering Society, Bremen, Germany.

Zero Configuration Networking (Zeroconf): www.zeroconf.org

Arne, B., & Stefan, B. (2010). Sensor Interface Descriptors. OpenGIS Discussion Paper.

Tom, O. (2009). MBARI. Retrieved from <http://www.mbari.org/pw/puck.htm>

Luis Bermudez, Eric Delory, Tom O'Reilly, Joaquin del Rio Fernandez. "Ocean Observing Systems Demystified"

OCEANS 2009 MTS/IEEE Biloxi, Biloxi, Mississippi, USA. October 26-29, 2009

Joaquín del Río, Yves Auffret, Daniel Mihai Toma, Shahram Shariat, Xavier André, Stéphane Barbot, Eric Menut, Yannick Lenault, Antoni Manuel, Oussama Kassem Zein, Joel Champeau, Dominique Kerjean. "Smart Sensor interface for sea bottom observatories". MARTECH'09.. INTERNATIONAL WORKSHOP ON MARINE TECHNOLOGY. November 2009.

PESOS Group Reports on the Activities in Regard to Standardization

Klaus Schleisiek (SEND Off-Shore Electronics GmbH - Rostocker Str. 20 - D-20099 Hamburg, Germany) (www.send.de)

Standardization

There are currently two standardisation directions in the ocean science observatory community, which are or will become relevant to us as equipment manufacturers: PUCK and IEEE1451. Up to now it cannot be foreseen whether either one will be accepted and enforced. However, the underlying concepts and architectures are of relevance for the implementation of ocean observatories.



Fig.8 - Underwater camera at OBSEA observatory. The system is remotely controlled via a standard communication link

PUCK

The first activity addresses the intelligence that should be added to an instrument (sensor) in order to automate its integration (or replacement) into an ocean-bottom system. To this end, MBARI has proposed the PUCK protocol (see: www.mbari.org/pw/puck.htm), which is quite mature and has been submitted to become an OGC (Open Geospatial Consortium) standard. From MBARI's website: "PUCK is a simple command protocol that helps to automate the configuration process by physically storing information about the instrument with the instrument itself. The stored information could be an instrument description (metadata), driver code, or any other information deemed relevant by the observing system.

When a PUCK-enabled instrument is plugged into a host computer the host can retrieve the information from the instrument through PUCK protocol and deal with the information appropriately. For example, the host may install and execute instrument driver code that has been retrieved from the instrument. We refer to this automated configuration process as plug-and-work."

At present PUCK protocol has been specified for RS232 interfaces only. Similar to the old days of the Hayes modem, PUCK defines an escape sequence, which gives access to 12 simple commands. The "PUCK datasheet" consumes 96 bytes and uniquely identifies the instrument such that the system controller can retrieve its metadata.

The "PUCK payload", if at all present, is an area of non-volatile storage space, which may be written and read using the PUCK protocol. It may actually hold the metadata, which is necessary to operate the instrument in a certain environment. Experiments have been made where the same sensor has been plugged into different ocean-bottom systems. Appropriate metadata had been stored for these environments and therefore, the instrument could be integrated into these environments automatically. I like PUCK. Because it is useful. Because it is simple. Because only a minimal set of properties is standardized and there is a lot of room for installation specific extensions. Its implementation into an existing instrument takes on the order of 10 engineering days. Given that enough flash memory is available, of course.

IEEE1451

The second activity addresses independence from any idiosyncratic way of manipulating instruments. Right now, instrument manufacturers have invented various proprietary ways of how their instrument must be controlled. Incompatible access philosophies and syntaxes prevail.

Pretty much like Postscript (PDF) solved the problem of hardware dependence for printing, a similar universally accepted language for manipulating ocean-bottom instruments would be nice to have, because it would simplify the integration of instruments into ocean observatories considerably. And it would allow to create „higher level“ control software (e.g. sensor web enablement), which could be used universally instead of being a „one off“ solution for one specific observatory.

In essence, what we need is an „ocean-observatory control language“ (OOCL), an abstract instrument (sensor) language, which would be able to address all aspects of potential ocean-observatory topologies. To this end, an Esonet workshop in Brest succeeded in devising a reference model for

ocean observatories, which covers all potential topologies. And therefore, it is quite complex (see: esonet.epsevg.upc.es:8080/1451/ref_model.html). This reference model can now serve as a touchstone in order to check the suitability of any proposed OOCL.

For a number of years, academia has discussed the IEEE1451 standard as a potential candidate for this OOCL. Originally, IEEE1451 has been designed as a standard for home automation and it is a NIST committee design. Therefore, it is extensive, complex and time-consuming to understand. Something, nobody wants to touch without being paid for. Furthermore, it became clear during the Brest workshop that IEEE1451 fails to address several properties, which are needed according to the reference model.

I venture to predict that eventually OOCL will resemble IEEE1451, because for too long and too often IEEE1451 has been hailed as the solution to an OOCL in discussions with funding agencies both in Europe and America. But only a subset of IEEE1451 will be suitable, and it will have to be extended in order to fulfill the needs of an OOCL.

Yellow Pages

In the framework of the ESONET project the „Yellow Pages“ have been created at Lisbon University (see: www.esonetyellowpages.com). This is a database on commercial products and services that are needed for ocean bottom systems. Short profiles for most companies in this field have already been entered. These are the main categories:

Sensors

ADCPs, Conductivity, CTDs, Current meters, Depth, DO sensors, Flow meters, Fluorometers, Hydrophones, Magnetometers, Multiparameters, PAR sensors, pH sensors, Pressure sensors, Redox, Sediment traps, Temperature, Tiltmeters, Transmissiometers, Turbidity, Water samplers.

Hardware components

Acoustic releases, Cameras (Figure 8), Connectors, Data loggers, Floats, Housings, Lasers, Lights, Underwater batteries, Underwater cables, Underwater switches.

Deep sea services

If your company is not yet listed in the Yellow Pages, please get in touch with support@esonetyellowpages.com. After registration you will receive a username and password, which allows you to login to the data base at the “MY EYP” tab. You can directly edit your existing entries; new entries will first be reviewed by the support team before being published. The Yellow Pages are a service of the ESONET project to the commercial community and therefore, entries in the Yellow Pages are free of charge.

As an added value to new customers, one of the data base fields is the “esonet reference”. If possible, this will hold links to users of the product in the ESONET community, who are willing to talk about their experience with the product.

Evaluation of Standards at Western Mediterranean Observatory, OBSEA

Joaquin del Rio¹, Tom O'Reilly², Daniel Mihai Toma¹, Antoni Manuel¹, Christoph Waldmann³, Eric Delory⁴

¹SARTI, Technical University of Catalonia UPC, joaquin.del.rio@upc.edu; ²MBARI; ³MARUM University; ⁴dBScale

Abstract- *IEEE-1451[1] and OGC Sensor Web Enablement (OGC SWE)[2] define standard protocols to operate instruments, including methods to calibrate, configure, trigger data acquisition, and retrieve instrument data based on specified temporal and geospatial criteria. These standards also provide standard ways to describe instrument capabilities, properties, and data structures produced by the instrument. These standard operational protocols and descriptions enable observing systems to manage very diverse instruments as well as to acquire, process, and interpret their data in a uniform and automated manner. We refer to this property as “instrument interoperability”. This paper describes integration and evaluation of MBARI PUCK protocol [3] at OBSEA [4,5] in Spain.*

Keywords- *MBARI PUCK Protocol, Instrument Interoperability, IEEE1451, OGC SWE*

Introduction

To achieve instrument interoperability, the physical instrument must be reliably associated with software and information that conform to standard protocols and descriptions. In most cases today, the “firmware” that is physically embedded within the instrument does not conform to standards; instead standards-compliant external instrument “driver” software and metadata files residing on observatory host computers are logically associated with the physical instruments. Setting up the logical association is typically a manual process; technicians must install instrument driver software on the host, specify a host data port where the instrument is installed, and specify baud rates, configuration files, and so on. This manual configuration process can be tedious, time-consuming, and hence prone to human error. Moreover the configuration process must sometimes be performed aboard ships and buoys under severe environmental conditions that challenge human physiology and psychology, thus increasing the chances for error.

An alternative approach is to embed the standards protocols physically within the instrument. In this case the instrument will respond appropriately to standard operations, and will supply descriptive information in standard format. Thus the observing system can automatically identify the instrument and utilize the instrument and its data when it is physically installed, and there is no need for technicians to manually set up a logical association between physical instrument and host drivers and configuration files. There are several chal-

allenges to this approach that can be solved by using standards such as IEEE1451, OGC SWE and MBARI PUCK protocol described below.

IEEE-1451 and OGC SWE

The IEEE 1451 provides a specification to add a digital layer of memory, functionality, and communication to sensors. For example it enables sensors to be controllable and their measurements accessible through a network with sufficient information on the sensor characteristics and history.

OGC Sensor Web Enablement (SWE) provides a specification to Web-enabled sensors to be accessible and, where applicable, controllable via the Web. SOS provides a broad range of interoperable capability for discovering, binding to, and interrogating individual sensors, sensor platforms, or networked constellations of sensors in real-time, archived or simulated environments.

IEEE-1451 and OGC SWE are rather complex, which is to be expected as these standards are also quite comprehensive. This complexity presents challenges for instrument manufacturers who must thoroughly understand the standard and who must correctly implement it in firmware. Moreover embedded instrument processors are often designed for low cost and low-power environments, and hence may not be capable of fully implementing the standards. Another drawback is that manufacturers would likely have to abandon existing instrument firmware that does not implement the standard; this existing firmware often represents a very considerable investment by the manufacturer. A third drawback is that IEEE-1451 and OGC SWE are still evolving, again due to the comprehensive nature of these standards. Thus either the standard revision process must be very carefully managed to ensure “backwards compatibility”, or instrument firmware must be occasionally upgraded to remain compliant with the latest standard. Both of these alternatives present non-trivial challenges to instrument manufacturers and standards bodies.

MBARI PUCK Protocol

A third approach is provided by MBARI PUCK protocol. PUCK provides low level operations to communicate with instruments. PUCK does not itself implement all the levels of interoperability from OGC SWE and IEEE 1451. PUCK defines a simple standard embedded instrument protocol to store and retrieve information from the instrument. The information consists of a minimal instrument datasheet that includes a universally unique instrument serial number, a manufacturer ID, and a small amount of other metadata. PUCK protocol also allows an optional “payload” consisting of any information needed by a particular observing system. The payload format and content are not constrained by PUCK protocol, and can include executable driver code that implements a standard operating protocol as well as metadata that describe the instrument in a standard way. Using PUCK protocol, technicians can store payload contents with the instrument before deployment. When the instrument is

deployed, payload is retrieved by the host and utilized appropriately; e.g. the host can execute the driver code, and can use or distribute the standard metadata to other locations on the network. Thus standard IEEE-1451 and OGC SWE components can be automatically retrieved and installed by the host when a PUCK-enabled instrument is plugged in, overcoming the difficulties of manual installation. PUCK protocol is simple, and readily implemented in even simple instrument processors; several manufacturers now implement MBARI PUCK protocol in their instruments, and report just a few weeks of engineering effort to do so. PUCK protocol augments rather than replaces existing instrument protocols, and manufacturers can usually implement PUCK by extending their existing protocol rather than starting from scratch. Since the protocol is simple, it is likely to be stable, so manufacturers do not have to modify firmware to keep up with an evolving standard. As higher-level IEEE-1451 and OGC SWE standards evolve, the instrument PUCK payloads can simply be updated through PUCK protocol. The PUCK protocol specification is available at <http://www.mbari.org/pw>.

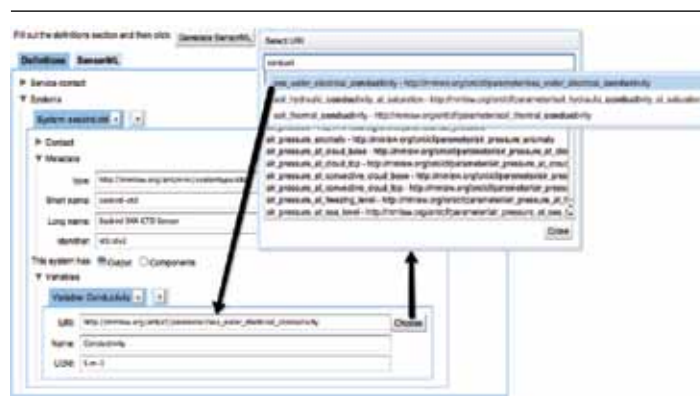

Fig.9 - Web interface to generate SensorML PUCK Payload

Puck Integration

Until recently, PUCK protocol was used exclusively on MBARI moored and cable-to-shore observatories. We describe tests to integrate and evaluate the protocol on non-MBARI systems as ESONET test-bed observatories such as OBSEA. We estimate the engineering effort required to integrate PUCK into these systems, and summarize the benefits gained for that effort. We discuss possible refinements to the protocol and describe plans to submit MBARI PUCK as a formal standard.

Puck Integration at Western Mediterranean Observatory, OBSEA, Spain

At OBSEA Observatory (Figure 3), two CTD are been used to test the integration of PUCK protocol. These instruments were a RBR CTD with PUCK implemented in firmware and

a Seabird CTD with an external PUCK hardware. Integration starts by developing the instrument metadata. Two different metadata files were implemented for each instrument: a SensorML file and a XML IEEE 1451 TEDS file. These files are stored in the PUCK payload memory. Each file is preceded by a tag that specifies the file type, as shown in Table 1 (the tag format and attributes will be proposed as an addendum to the PUCK version 1.3 specification)

Table 1.
Recommended Payload type name

Payload Type	Description
IEEE-1451- binary- TEDS	IEEE-1451 TEDS (binary format)
IEEE-1451-xml-TEDS	IEEE-1451 TEDS (XML format)
SWE-SensorML	SensorML format
MBARI-SIAM	MBARI SIAM JAR file

A web-based tool is being developed to simplify creation of SensorML and IEEE 1451 TEDS files for specific instruments, using consistent syntax and attribute names.

The user indicates the structure of the sensor system (system type, variables, and subsystems) while being able to choose URIs (Uniform Resource Identifiers) via drop-down lists containing standard entries for sensor types and variables, and then the tool generates the resulting document.

The drop-down lists are populated with definitions registered in the MMI Ontology Registry and Repository, ORR, <http://mmisw.org/orr>.

Figure 9 illustrates the basic interaction with the definition of an output variable. The user clicks a button to select an appropriate definition from the NetCDF Climate and Forecast (CF) Metadata Convention standard name vocabulary (<http://cf-pcmdi.llnl.gov/>). A similar selection mechanism is available for sensor types. The tool allows the description to include nested subsystems, each with the corresponding variables. Once the desired structure has been completed, the "Generate SensorML/TEDS" button creates a file that can then be stored in an instrument's PUCK payload.

The communication between instruments (in this case 2 CTDs) and the NCAP host computer is implemented by a serial RS232 link. The host computer is running an IEEE1451.0 HTTP server and an automatic instrument recognition algorithm to automatically detect a new instrument plugged into a serial port. This detection protocol is shown in figure 10.

The host computer periodically interrogates the serial port for a PUCK-enabled instrument.

When the host receives a PUCK response from the serial port, the host retrieves the 96-byte PUCK datasheet and examines the UUID to determine if a new instrument has been installed. If so, the host retrieves the SensorML and IEEE 1451 TEDS description from the instrument's PUCK payload, and loads an appropriate driver.

Finally the driver retrieves a new data sample from the instrument. These operations are performed at the sampling frequency specified for the instrument.

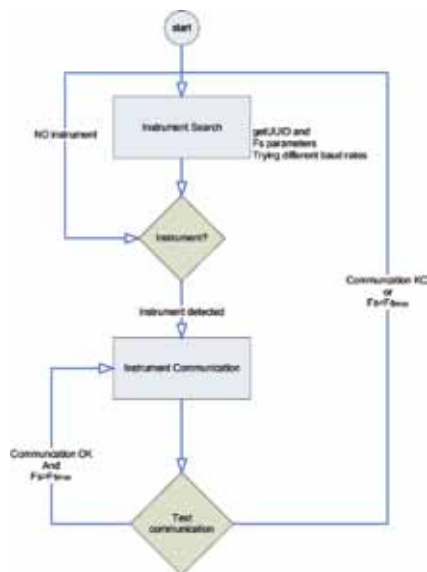

Fig.10 - Automatic Instrument Recognition protocol

The IEEE1451.0 HTTP server running on the NCAP host computer keeps track of instruments or TIMs connected to the NCAP serial ports. A web application based in Google Maps retrieves the information from the NCAP using IEEE1451.0 commands such as "http://esonet.epsevg.upc.es:1451/1451/Discovery/TIMDiscovery?ncapId=4&responseFormat=xml" and ReadTIMGeoLocationTEDS command in order to mark the position of the instrument in the Map as is shown in Figure 10.

In addition a Sensor Observation Service (SOS) runs on the NCAP host computer, in parallel with the IEEE1451.0 server. This SOS updates its properties about the number of instruments connected to the host. An SOS client such as Compusult's SenseEarth (<http://senseearth.ca/>) retrieves the SensorML instrument description originally stored in the instrument PUCK, thereby visualizing information geographically in a Google Maps application and reading data from the instruments. Figure 11 shows the schema of the instruments and services running the SOS and Figure 12 shows a Compusult SOS client used to visualize real-time data.

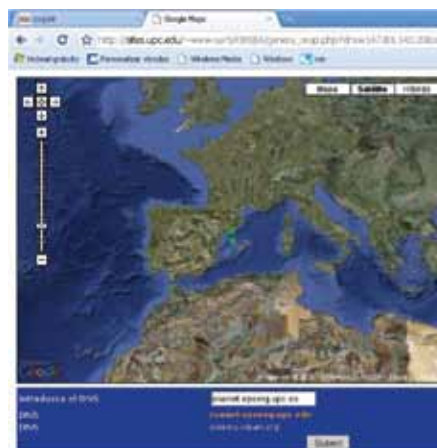

Fig.12 - Google Maps application to show instrument availability

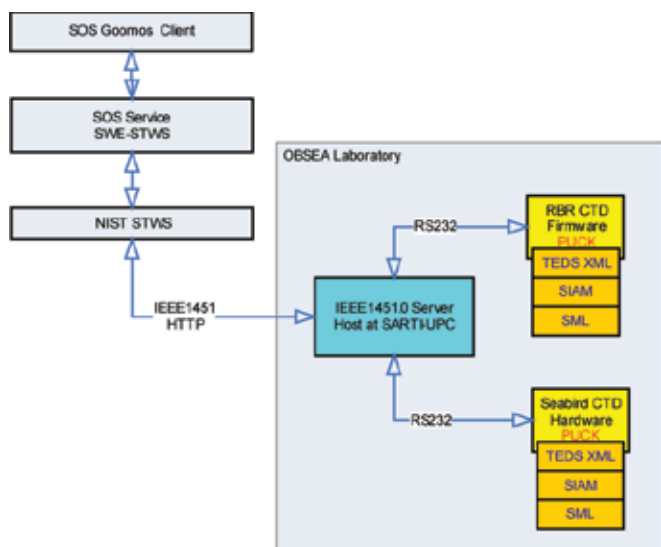

Fig.11 - Block Diagram of the Test Bench

Conclusions

PUCK Protocol can co-exist and it is compatible with other existing standards as IEEE1451 or SWE – SOS. The use of PUCK protocol within an instrument facilitate the integration of the instrument within an observatory allowing storage of the description of the instrument metadata in different payloads types as IEEE1451 XML TEDS or SensorML. The engineering effort required integrating a PUCK enable instrument into and observatory is very small. Within a working day a computer science engineer is able to understand and communicate with a PUCK enable instrument, storing and configuring its payload. Approximately one week is enough time to define the payload and generate the code to be ready to integrate the instrument into the observatory. An automatic instrument recognition protocol has been proposed in order to enable the host to automatically configure a new instrument using PUCK Protocol and different Payload types.



Fig.13 - SOS Client from Compusult

References:

- [1] Lee, K., "IEEE 1451: A Standard in Support of Smart Transducer Networking", Proceedings of the 17th IEEE Instrumentation and Measurement Technology Conference, Baltimore, MD, May 1-4, 2000, Vol. 2, p.525-528
- [2] George Percivall, Carl Reed "OGC® Sensor Web Enablement Standards", Sensors & Transducers Journal, Vol.71, Issue 9, September 2006, pp.698-706, ISSN 1726-5479
- [3] Kent L. HEADLEY, Dan DAVIS, Duane EDGINGTON, Lance McBRIDE, Thomas C. O'REILLY, Michael RISI "Managing Sensor Network Configuration and Metadata in Ocean Observatories Using Instrument Pucks" Third International Workshop on Scientific Use of Submarine Cables and Related Technologies, 25-27 June 2003
- [4] Marc Nogueras, Carola Artero, Joaquín del Río, Antoni Mànuel, David Sarrià, "Control and acquisition system design for an Expandable Seafloor Observatory", IEEE OCEANS09, 11-14 May, Bremen, Germany
- [5] M. Nogueras, J. Santamaria, A. Mànuel, "Construction of the OBSEA cabled Submarine Observatory" Instrumentation Viewpoint, Num.6, pp33-34, autumn 2007.
- [6] T.O'Reilly, K.Headley et al, "MBARI technology for self-configuring interoperable ocean observatories", Proceedings of the Marine Technology Society / Institute of Electrical and Electronics Engineers Oceans Conference, Boston, Massachusetts
- [7] Rueda, C., Bermudez, L., Fredericks, J. The MMI Ontology Registry and Repository: A Portal for Marine Metadata Interoperability. MTS/IEEE Oceans'09. Biloxi, Mississippi. October, 2009.

Excerpts from "Instrument Interface Standards for Interoperable Ocean Sensor Networks"

T.C. O'Reilly¹, K. Headley¹, D.R. Edgington¹, C. Rueda¹, K. Lee², E. Song², J. Zedlitz³, J. del Rio⁴, D. Toma⁴, A. Manuel⁴, E. Delory⁵, C. Waldmann⁶, S. Fairgrieve⁷, L. Bermudez⁸, E. Bridger⁹, P. Bogden⁹, A. Amirault¹⁰

¹Monterey Bay Aquarium Research Institute (*oreilly@mbari.org*), ²National Institute of Standards and Technology (*kang.lee@nist.gov*), ³Christian Albrechts University at Kiel (*jze@informatik.uni-kiel.de*), ⁴Polytechnic University of Catalunya (*joaquin.del.rio@upc.edu*), ⁵dBscale (*eric.delory@dbscale.com*), ⁶University of Bremen (*waldmann@marum.de*), ⁷Northrop Grumman Corporation (*Scott.Fairgrieve@ngc.com*), ⁸SURA (*bermudez@sura.org*), ⁹GoMOOS (*eric@gomoos.org*), ¹⁰Compusult Ltd (*angela@compusult.net*).

Transducer Electronic Data Sheet (TEDS)

The transducer electronic data sheet ("TEDS") is a key concept of IEEE 1451. A TEDS describes characteristics and

capabilities of components such as transducers, TIMs, and communications links in a standard way. Applications can retrieve the TEDS through the IEEE 1451 protocols to dynamically discover instruments, sensors, and actuators as well as other system characteristics.

IEEE 1451.0 defines the TEDS formats for the family of IEEE 1451 standards. The IEEE 1451.0 TEDS are classified into mandatory and optional TEDS. The mandatory TEDS include Meta TEDS, Transducer Channel TEDS, PHY TEDS, and User Transducer Name TEDS. The optional TEDS include Calibration TEDS, Frequency Response TEDS, Transfer Function TEDS, Manufacturer-defined TEDS, End User Application-specific TEDS, and Text-based TEDS, which include Meta ID TEDS, Transducer Channel ID TEDS, Calibration ID TEDS, Command TEDS, Location and Title TEDS, and Geo-location TEDS.

oriented architecture (SOA) and the IEEE 1451.0 transducer services. The STWS WSDL specification is divided into six major elements: definitions, types, messages, portType, binding, and service. The STWS provides a unified Web service for IEEE 1451 smart transducers. The STWS component could reside in a separate computer to serve an IEEE 1451 smart transducer as shown in section (a) of Figure 14. It can reside in an NCAP to serve an IEEE 1451-based sensor network as shown in section (b) of Figure 14. The STWS component could also reside in an integrated IEEE 1451 smart transducer as shown in section (c) of Figure 14. The STWS provides a standard way to achieve interoperability of IEEE 1451 smart transducers with sensor applications.

OGC Sensor Web Enablement

A sensor web (Figure 15) refers to Web-accessible sensor networks and archived sensor data that can be discovered and accessed using standard protocols and Application Program Interfaces (APIs).

The Open Geospatial Consortium - Sensor Web Enablement (OGC-SWE) group is building a framework of open standards to exploit Web-connected sensors and sensor systems, such as flood gauges, air pollution monitors, stress gauges on bridges, satellite-borne earth imaging devices, oceanographic instruments, and other sensors and sensor systems. The OGC-SWE initiative focuses on developing a set of standards to enable the discovery, exchange, and processing of sensor observations and tasking of sensor systems. The OGC-SWE members have developed and tested the following specifications:

- Observations and Measurements (O&M) – Standard conceptual model and XML schema to encode observations and measurements. O&M defines an “observation” as an event whose result is an estimate of the value of some property of a feature of interest, obtained using a specified procedure. A sensor, channel, or systems of sensors could all be treated as a procedure. Data interoperability between instruments can be achieved with the O&M standard.
- Sensor Model Language (SensorML) – Standard conceptual model and XML schema to describe sensors, systems, and processes; provides information needed for discovery of sensors, location of sensor observations, configuration of sensor networks, processing of low-level sensor observations, and listing of “task-able” processes
- Transducer Markup Language (TransducerML or TML) – Conceptual model and XML schema to describe transducers and real-time streaming of data to and from sensor systems.
- Sensor Observation Service (SOS) - Standard web service interface for requesting, registering, filtering, and retrieving observations and sensor system information. SOS is the intermediary between a client and an observation repository or near real-time sensor channel.
- Sensor Planning Service (SPS) – Standard web service interface for requesting user-driven acquisitions and observations. SPS is the intermediary between a client and a sensor collection management environment.
- Sensor Alert Service (SAS) – Standard web service interface for publishing and subscribing to alerts from sensors.
- Web Notification Service (WNS) – Standard web service interface for asynchronous delivery of messages or alerts from SAS and SPS web services and other elements of service workflows.

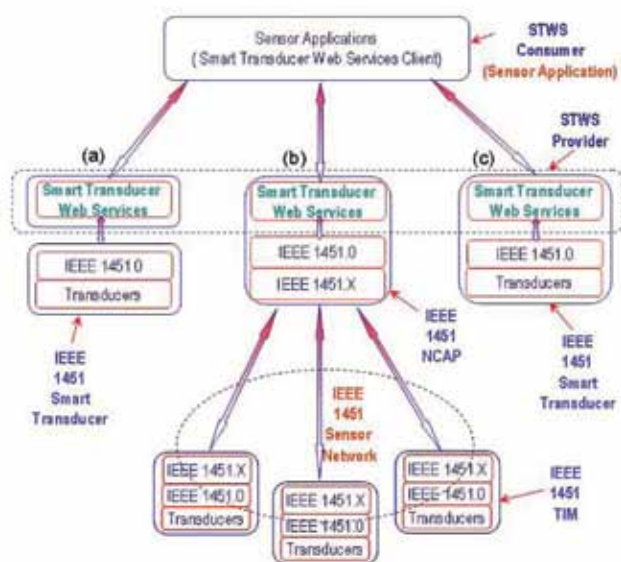

Fig.14 - STWS unified web service for IEEE 1451 smart transducers.

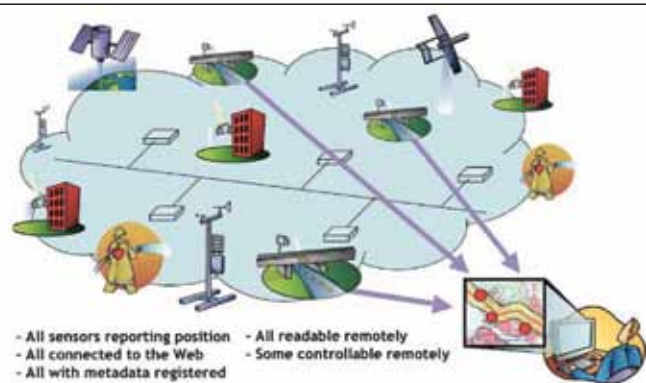

Fig.15 - Sensor web (courtesy of OGC).

Smart Transducer Web Service (STWS)

The STWS consists of a set of web services for accessing IEEE 1451 smart transducers. The STWS described in Web Service Definition Language (WSDL) is based on service-

SensorML

SensorML is a key component of SWE, providing standard sensor models and an XML encoding to describe any process associated with a sensor. All processes define their inputs, outputs, parameters, methods, and relevant metadata. SensorML models detectors and sensors as processes that convert real phenomena to data. It provides a functional model of a sensor system, rather than a detailed description of its hardware. It also treats sensor systems and the system's components (e.g., sensors, actuators, platforms, etc.) as processes. Thus, each component can be included as a part of one or more process chains that can either describe the lineage of the observations or provide a process for geo-locating and processing the observations to higher level information. In addition, SensorML provides additional metadata that are useful for enabling discovery, identifying system constraints, providing contacts and references, and describing "taskable" properties, interfaces, and physical properties.

Integration of IEEE 1451 and OGC-SWE

While the IEEE 1451 suite of standards deals with sensor metadata and sensor data from physical sensors to the network, OGC-SWE brings sensor information into Web applications. Applying both sets of standards will ultimately achieve the ease of use of sensors and ability to transfer sensor information from physical sensors to applications in a seamless manner using consensus-based standards. The question is how to apply or integrate IEEE 1451 and OGC-SWE to achieve instrument interoperability. The STWS is the proposed method to seamlessly integrate IEEE 1451 standards with the OGC-SWE standards and other sensor applications. The OGC Web Services 5 interoperability exercise focused on integration of SWE interfaces and encodings into workflows to demonstrate the ability of SWE specifications to support operational needs. OWS-5's "Team-1451" implemented and demonstrated the integration of IEEE 1451-based smart sensors and the SWE Web Services through the STWS.

Interoperable Test-Bed

Description of Interoperable Test-Bed

We have developed an interoperable instrument test-bed in collaboration with OGC and some members of the Sensor Standards Harmonization Working Group (SSHWG) led by the National Institute of Standards and Technology (NIST). The goal of this effort is to demonstrate how IEEE 1451, OGC Sensor Web Enablement, and MBARI PUCK protocols can be integrated to rapidly acquire, fuse, and assess data from a diverse set of instruments and individual observatories. The test-bed was originally demonstrated at the 2008 Ocean Innovations Interoperability Workshop and has since been refined and most recently demonstrated at the 2009 NSF Ocean Observing Initiative Instrumentation Workshop.

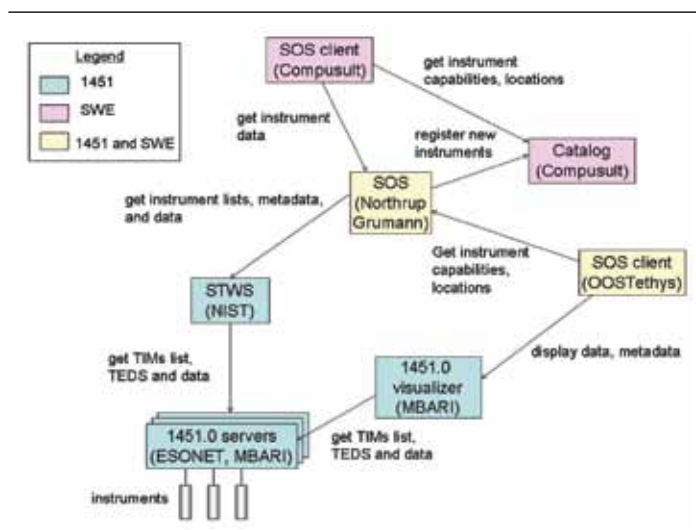

Fig.16 - Interoperable instrument test-bed architecture.

The test-bed currently integrates individual observatories at four different institutions in the USA and Europe into a single sensor network (Table II). Three of these observatories are associated with the European Seafloor Observatory Network (ESONET) and are located in Spain and Germany.

The fourth is located at the Monterey Bay Aquarium Research Institute (MBARI) in California USA.

Each individual observatory contains multiple instruments and independently-developed software components, some of which do not conform to recognized standards. However, team-members at each observatory have implemented IEEE 1451 "adapter" software that maps between IEEE 1451.0 protocol and their observatory protocols. Thus Internet applications that recognize IEEE 1451.0 can access the observatories' instruments through an IEEE 1451.0 server associated with each observatory (lower left corner of Figure 16).

Table II.
Test-Bed Observatories and Instruments

Observatory	Instrument
UPC-SARTI (Vilanova, Spain)	SBE37-SM CTD
University of Bremen (Germany)	Sea and Sun CTD SBE37-SM CTD
Christian Albrechts University at Kiel (Germany)	Sea and Sun CTD IFM GeoMar meteorological instruments
MBARI (USA)	SBE37-SM (w/PUCK) RBR XR420 CTD (w/PUCK) WETLabs Triplet fluorometer (w/PUCK) ASIMET wind sensor

One such application is the STWS, which provides a bridge between OGC-SWE protocol and IEEE 1451.0.

Thus OGC-SWE components such as a Sensor Observation Service (SOS) can access the individual observatory instruments through the STWS.

The current test-bed utilizes just a subset of IEEE 1451.0, including methods to discover TIMs on each NCAP, retrieve various TEDS, get the geo-location of each TIM, and acquire data from each TIM channel.

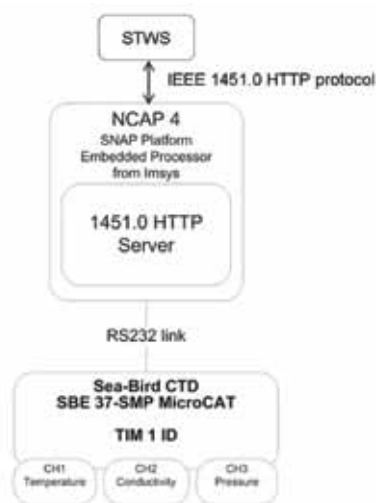

Fig.17 - UPC-SARTI observatory architecture.

Figure 17 schematically depicts the UPC-SARTI observatory which is a prototype for the OBSEA cable-to-shore observatory to be deployed in the western Mediterranean Sea in 2010. The UPC-SARTI NCAP executes the IEEE 1451.0 server and instrument drivers. One or more RS-232 instruments are plugged into the NCAP. The server and instrument drivers treat the attached instruments as IEEE 1451 TIMs, each TIM containing one or more transducer channels.

The NCAP is implemented by a very low-power yet capable Imsys Technologies SNAP module and the server and drivers are implemented in Java J2ME. The server can be reconfigured as instruments are installed or removed from the NCAP. For demonstration purposes, the observatory's Seabird CTD sensor can be installed in a hyperbaric chamber to simulate varying water depth. The basic UPC-SARTI design is heavily influenced by IEEE 1451. In contrast the MBARI observatory provides an example of a "legacy" system. Over the past several years MBARI has developed and deployed observatory middleware called "SIAM" for use on its moored observatories (MOOS) as well as the MARS cable-to-shore observatory.

For each physical instrument in the observatory, SIAM provides an instrument driver that presents a generic "service" interface to clients on a TCP/IP network. Similar in design philosophy to IEEE 1451, the SIAM instrument service interface comprehensively defines how clients configure, control, and retrieve data from the associated instrument.

Clients request these operations through the generic interface, without having to know the native instrument serial

protocol, as those details are "hidden" by the SIAM instrument drivers. SIAM also recognizes MBARI PUCK protocol and automatically retrieves driver code and instrument metadata from an instrument that implements PUCK, thus achieving "plug and work" behavior.

SIAM has proven very useful and extensible over the past several years. The interoperability test-bed thus presents an excellent opportunity to integrate a "legacy" system (SIAM) with standard interfaces (IEEE 1451, OGC-SWE). In our test-bed the SIAM software executes on a MBARI Mooring Controller (MMC), which implements an IEEE 1451 NCAP (Figure 18). Instruments are plugged into serial ports on the MMC.

The MBARI IEEE 1451.0 server runs on a workstation host on the MBARI network and communicates with the SIAM instrument services via Java Remote Method Invocation (RMI).

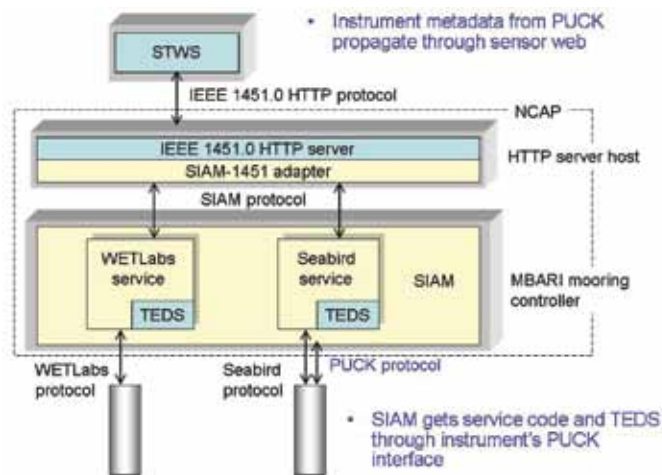

Fig.18 - MBARI SIAM observatory adapted to IEEE 1451.0.

To integrate SIAM with IEEE 1451.0, the MBARI developers implemented an "adapter" component that maps between IEEE 1451.0 requests coming through the server and methods in the SIAM service interface (Figure 18). Given the similar design philosophy between SIAM and IEEE 1451.0, the mapping between the two protocols is straightforward.

Thus when the IEEE 1451.0 server receives a client request, it issues appropriate method calls to the SIAM instrument service(s), transforms the values returned by the instrument service to IEEE 1451.0 format, and returns the values to the IEEE 1451.0 client.

The MBARI developers also slightly extended the SIAM instrument service classes to incorporate the IEEE 1451 "transducer" concept.

SIAM recognizes PUCK protocol and retrieves the payload of a PUCK-enabled instrument when the device is plugged in. For the test-bed, metadata needed by the various IEEE 1451 TEDS are stored in the instruments' PUCK payload, automatically retrieved by SIAM when the instrument is installed, and transferred to IEEE 1451.0 clients (including the STWS) on request. Thus metadata retrieved from the instrument itself through PUCK protocol is propagated across the sensor web.

Test-bed Performance

The current test-bed relies on polling between SWE and IEEE 1451 components to update states across the system. This is because the current SOS v1.0 specification does not support asynchronous operations; instead, the SOS relies on a typical web service HTTP POST request/response mechanism for retrieving sensor information and observations. This approach can be quite inefficient, as reflected in sometimes sluggish performance of SWE clients. Asynchronous event notification between IEEE 1451 and SWE would enable much more timely and efficient update of SWE clients when instruments are installed into the network, change their position, acquire a sample, or otherwise change in an asynchronous way.

Existing OGC-SWE specifications such as the Sensor Alert Service and Web Notification Service support asynchronous notifications, and the OGC is investigating ways of incorporating asynchronous operations in future versions of the SOS and other OGC specifications.

The current SOS implementation relies on many requests to the STWS in order to retrieve the latest information regarding available IEEE 1451 sensors.

Information from the STWS is used to populate the SOS Capabilities document, which tells SOS clients what sensors and observations are available, as well as SensorML documents describing the sensors themselves and O&M observations describing the data coming from those sensors.

The current implementation employs caching of many of the STWS responses in order to maximize efficiency, but more effective caching can be added to further improve efficiency. Caching can also be used on the SOS client to minimize the number of new requests that need to be made to the SOS in order to discover and describe sensors.

The current test-bed utilizes high-speed network links throughout. A more realistic design will incorporate low-bandwidth intermittent links to simulate satellite communications for moorings and perhaps acoustic links for underwater applications.

IEEE 1451 TEDS and SensorML

IEEE 1451 and OGC-SWE each provide a metadata framework to describe the characteristics of sensors. IEEE 1451 TEDS focus primarily on physical characteristics of sensors, instruments, and communication links which are closely associated with TIMs, whereas SensorML is applicable to high-level applications. SensorML provides a more comprehensive model that includes complex characteristics such as sensor data processing procedures and data acquisition schedules. Individual observatories in the current test-bed have no explicit notion of OGC-SWE and provide only TEDS to the IEEE 1451.0 layer. (The TEDS are subsequently mapped to basic SensorML elements by the Northrop Grumman SOS).

However, the additional sensor information provided by SensorML (but apparently not by TEDS) can be extremely valuable in a broader sensor web. Hu et al describe a TEDS-to-SensorML mapping scheme but also point out the complexities and limitations of their approach. An alternate approach could add a method to transfer “opaque” metadata

through IEEE 1451.0. In our case, the observatory could transfer a SensorML document by this method.

In any case, the TEDS-to-SensorML integration problem requires more research.

Additional Functionality

The test-bed currently emphasizes data interoperability. As a next step we plan to demonstrate the capability to configure and operate instruments through a standard Internet interface.

This step will require integration and perhaps modification of the Sensor Planning Service and IEEE 1451 standards.

Thus far, the test-bed implements only a few methods in the IEEE 1451.0 standard; we plan to add more functionality in the future. Most of the test-bed instruments return raw data with a fixed and simple format that is easily mapped to the IEEE 1451.0 standard data format. We also plan to integrate instruments, such as acoustic doppler current profilers (ADCP) that generate more complex data structures.

CAN standards

Controller Area Network (CAN) was originally developed as a bus architecture for automobiles, but today is used in a wide variety of applications. The CAN-bus network provides a very efficient and robust platform for deterministic real-time applications of distributed sensors and actuators. Key advantages provided by CAN-bus include robust and efficient error detection and message transmission protocols. CAN-bus is based on OSI Reference Model layers 1 and 2 (physical and data link layers) and is standardized in ISO 11898.

Several application-level standards have been developed to run on CAN-bus, notably the CANopen communication protocol and device profile specification.

Several oceanographic applications that use CAN-bus and CANopen for onboard communications have been implemented, including autonomous underwater vehicles and buoys, and at least one manufacturer supplies oceanographic instruments for CAN-bus. We would like to investigate the use of CAN standards for future systems as well.

CANopen “device profiles” have been specified for several kinds of devices, including sensors and actuators. Every CANopen device profile specifies an “object dictionary” that describes all parameters and variables of that device. Objects can be simple data-types such as bytes, integers, floating point values, and strings, but also more complex data types like arrays. Some dictionary objects are mandatory, others are optional. The object dictionary is stored in a TEDS-like electronic data sheet.

CANopen bears conceptual similarities to IEEE 1451. For example, in addition to the TEDS-like device profiles, CANopen’s “CAN-master” component is responsible for managing network communications between devices and the network, similar to the IEEE 1451 NCAP.

Unfortunately the IEEE 1451.6 CAN-bus working group is no longer active.

Nevertheless we could explore integration of CAN with OGCSWE standards, e.g., by “mapping” CANopen electronic data sheets to SensorML.

EsoNet News Technology

*Oceanlab Aberdeen, 2-3rd November 2010
Anne Holford, (a.holford@abdn.ac.uk).*

A technology workshop was held at Oceanlab, Aberdeen, for members of ESONET/EMSO, EuroSITES and KM3NeT programmes. Among the topics covered were cable infrastructures and junction boxes, standalone benthic and water column observatories and future technologies.

A presentation on the Ifremer EMSO junction box activities was given and an update on the Obsea test bed observatories was presented. Oceanlab gave a presentation and demonstration of their inductive coupling junction box to be installed in the Ythan estuary in 2011 as part of the University of Aberdeen's environmental monitoring Ythan observatory. KM3NeT provided a presentation on how the power and data requirements were quantified for their technical design and the envisaged network architecture proposed to meet those requirements.

Other topics discussed were stand alone observatories such as MODOO and Delos, and the use of acoustic modems for data transfer. KM3NeT presented the optical fibre data transfer and time stamping system use for the telescope detection units. An update on the current status of plug and play interfaces and smart sensors was given.

Some recommendations were agreed on AC versus DC power supplies, types of connectors, acoustic modem energy efficiencies, the ESONET generic sensor package, and data access policy. These are to be presented at the ESONET best practice workshop in Marseille in December.



The Oceanlab inductive coupling prototype.

WPE Meeting

*Paris 11-13th October 2010,
Piera Sapienza (sapienza@lns.infn.it)*

KM3NeT researchers met in Paris last October in the frame of the KM3NeT Preparatory Phase working package that deals with the definition and organisation of the KM3NeT Marine, Environment and Geosciences Observatory. During the meeting some of the key issues for the exploitation of KM3NeT infrastructure as a multidisciplinary cabled observatory system sciences were pointed out and addressed. To design the KM3NeT infrastructure in order to be suitable also for multidisciplinary use, many technical aspects have to be studied into details. In particular, specifications for junction boxes and connections, power requirement, voltage output, bandwidth, data format etc. are needed. Moreover, procedures during installation, operation and maintenance has to be defined.

In the three KM3NeT candidate sites, Toulon, Pylos and Capo Passero, deep-sea infrastructures have been already installed and are in operation and therefore these sites are of interest for EMSO.

An agreement between KM3NeT and EMSO concerning the sites of mutual interest will allow an optimal design of the infrastructure for a synergic use. The KM3NeT/EMSO collaboration could be governed by a Memorandum of Understanding allowing for a co-ordinate use of the infrastructure.

EsoNews is a publication from ESONET Network of Excellence
Executive Editor: J. M. Miranda
Design and desktop publishing: Sandra Martins
Printed at Cmyk - Artes gráficas • Print run: 1200
ESONET Office • IFREMER Centre de Brest, BP 70 29280 Plouzané,
FRANCE • Tel: + 332 98 22 40 96 - Fax: + 332 98 22 46 50
email: esonet-coordinator@ifremer.fr - URL: <http://www.esonet-emso.org>
To receive the ESONEWS letter by Email, send an Email to sympa@ifremer.fr,
with <SUBscribe esonews> in the subject, if you are not already registered
This newsletter is printed in recycled paper

